

Biology 305 Genetics
Practice Problems for the Human Genetics Section

You are studying a dominant neurodegenerative disease called Sievebrain. As part of your studies, you have been searching for families in which Sievebrain is present and seems to segregate. One pedigree of a family he identified is shown below, segregating for Sievebrain (filled symbols) and unaffected (open symbols) and alleles at a marker locus: :A, B, C, and D. Assume that the affected male in generation I received A and the Sievebrain disease from one of his parents.

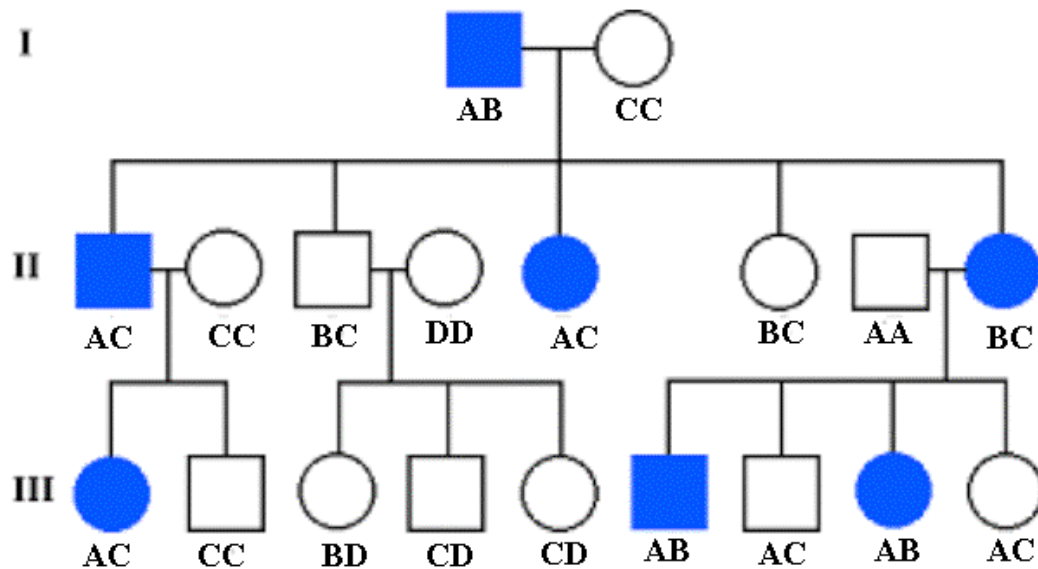

- Which allele of the marker seems to be linked with Sievebrain affected individuals in the second generation (II)?
- Do any of the individuals in this generation (II) appear recombinant?
- Does the phase (allele association) change in any of the families whose children are shown in the third generation?
- Does this imply that all of the children in this family are recombinant?

You were eventually able to find 15 families in which Sievebrain was segregating. Another group has produced data that suggests the Sievebrain locus is located on chromosome 21. Therefore you tested for linkage of Sievebrain to short tandem repeat (STR) markers (micro- and mini-satellite markers) that have been mapped to chromosome 21. Some of your data is shown in the LOD score table below.

STR locus	#informative families	θ				
		.05	.1	.2	.3	.4
a	3	0.35	1.33	1.38	1.45	1.21
b	8	0.12	0.22	0.41	0.85	0.37
c	10	0.85	1.62	3.85	4.10	2.42
d	9	-3.21	-1.11	-1.02	-0.45	-0.01
e	11	7.90	5.20	4.80	1.20	0.05
f	6	0.80	1.25	2.40	3.35	3.10
g	4	-1.45	0.01	0.12	2.44	2.20
h	12	-10.71	-8.21	-5.16	-2.23	0.20
i	6	1.21	1.76	3.04	1.65	0.45
j	3	1.90	1.20	0.80	0.20	0.05
k	2	0.91	0.98	1.35	1.45	1.10

- f) Which of the loci show strong evidence of linkage, and why?
- g) Which of the STR loci show at least suggestive evidence of linkage (state your criteria for suggestive linkage).
- h) If Sievebrain actually is on chromosome 21, why don't all of the STR loci show significant evidence of linkage?
- i) Which of these STR loci would you use for further attempts to identify the Sievebrain locus on the physical map of chromosome 21, and why? (2 pts)
- j). When you examine the data on the chromosome 21 physical map of your STR loci, you find that STR loci c and k are located in almost the same position on chromosome 21. Why do they not have similar LOD values?
- k) Why are none of the STR loci tested in all 15 informative families, since each of the families is segregating for the disease?